

This Page Is Inserted by IFW Operations  
and is not a part of the Official Record

## **BEST AVAILABLE IMAGES**

Defective images within this document are accurate representations of the original documents submitted by the applicant.

Defects in the images may include (but are not limited to):

- BLACK BORDERS
- TEXT CUT OFF AT TOP, BOTTOM OR SIDES
- FADED TEXT
- ILLEGIBLE TEXT
- SKEWED/SLANTED IMAGES
- COLORED PHOTOS
- BLACK OR VERY BLACK AND WHITE DARK PHOTOS
- GRAY SCALE DOCUMENTS

**IMAGES ARE BEST AVAILABLE COPY.**

**As rescanning documents *will not* correct images,  
please do not report the images to the  
Image Problem Mailbox.**

# PATENT SPECIFICATION

586,919

Application Date: March 28, 1944. No. 5717/44.

Complete Specification Left: April 30, 1945.

Complete Specification Accepted: April 8, 1947.

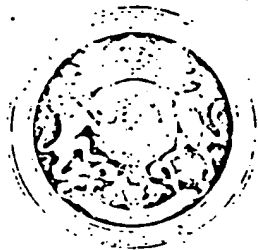

## PROVISIONAL SPECIFICATION

### Improvements in and relating to Bottle Capping and to Closures therefor

We, ARTHUR GRAHAM-ENOCK, a British subject, and GRAHAM-ENOCK MANUFACTURING COMPANY LIMITED, a Company registered under the laws of Great Britain, all of the Company's address at Margaret Street Works, Windus Road, Stamford Hill, London, N.16, do hereby declare the nature of this invention to be as follows:—

10 This invention relates to bottle capping wherein the closure comprises a metal disc such as a thin aluminium disc which is inherently non-rigid.

Hitherto it has been the practice to combine with the capping machine mechanism for cutting or punching the metal discs from a sheet and to form them into a cup shape to facilitate their being fed to the capping position by the aid of the bottles.

20 According to another arrangement in which a stiffer metal disc is used the discs are preformed and are located in the capping machine in a stack from the lower end of which the discs are successively fed by suitable means to the mechanism for applying the closure to the bottle.

An object of the present invention is to provide an improved closure element formed of aluminium or the like whereby such may be preformed and arranged in stacks in containers, whereby the necessity of incorporating a disc forming mechanism in the capping machine is avoided.

35 According to the invention, a closure disc of aluminium or like metal is rendered substantially rigid by impressing therein corrugations or like formations adapted to resist bending of the disc whereby the disc may be conveyed over a surface by a force applied edgewise in the plane of the disc and may be delivered from a stack or magazine of preformed discs.

The corrugations or formations are preferably arranged to leave a plain marginal band and the periphery is preferably slightly turned down.

45 According to another feature, a series of closure discs is provided with stiffening corrugations or formations comprising at least two distinct designs whereby they are anti-nesting so that a plurality of discs may be stacked, each disc in the stack

having a design different from that of adjacent discs.

The invention also consists in means for 55 embossing stiffening and anti-nesting formation on aluminium or like discs and for stacking them in suitable containers comprising a pair of disc forming and embossing machines for alternate operation 60 and from which the discs are fed alternately to a stacking position.

In carrying the invention into effect according to one convenient mode by way of example as applied to the capping of 65 milk bottles, the closures comprise aluminium discs which are pressed or cut out of sheets of aluminium foil of a suitable gauge. The normal gauge, it is appreciated, is such that the discs have 70 substantially no inherent stiffness and in order to provide the necessary stiffness for use, according to this invention, during the pressing operation the discs are provided with stiffening corrugations or 75 formations or embossing which may cover substantially the whole while leaving a peripheral margin free. The edge may be slightly turned or cupped down.

The design of the stiffening corrugations 80 or formations may vary and may be of regular or irregular character, and with a view to avoiding nesting of the corrugations it is preferred to provide at least two distinct designs. Thus one set of discs 85 may have radial embossments combined with a pair of concentric circles while another set may have a spiral or a series of concentric circles.

The embossing formations are such that 90 the discs are rendered somewhat resistant to bending sufficient to stand up to an edgewise feeding pressure during the capping operation.

By having at least two different designs 95 it will be appreciated that placing discs having alternate designs in a stack they will not nest one within the other. The depth of the embossing formations are such that when stacked the edges of the discs 100 will be spaced to permit the insertion of feeding means or knives between adjacent discs.

The discs are adapted to be stacked in

[Price 1/-]

suitable containers or cartons and for this purpose where two designs of embossments are adopted a pair of disc forming and embossing machines or presses may be provided.

These presses may be arranged at an angle to one another and are provided with suitable dies to form the corrugations or other stiffening formations, each die having a distinct design. The dies are such that plain marginal bands are left on the discs while the edges of the discs are

turned down or slightly cupped. The plungers of the presses are adapted for alternate operation and may be actuated by a common cam means.

The embossed discs as delivered are stacked in a container or carton.

It will be obvious that two opposed series of presses may be provided so that a plurality of stacks of discs may be simultaneously formed.

Dated this 28th day of March, 1944.

MARKS & CLERK.

### COMPLETE SPECIFICATION

#### Improvements in and relating to Bottle Capping and to Closures therefor

We, ARTHUR GRAHAM-ESOCK, a British subject, and GRAHAM-ESOCK MANUFACTURING COMPANY LIMITED, a Company registered under the laws of Great Britain, all of the Company's address at Margaret Street Works, Windus Road, Stamford Hill, London, N.16, do hereby declare the nature of this invention and in what manner the same is to be performed, to be particularly described and ascertained in and by the following statement:—

This invention relates to bottle capping wherein the closure element or disc comprises a thin metal disc such as aluminium or other suitable metal foil.

An object of the present invention is to provide an improved closure element of aluminium or other suitable metal foil which it is possible to feed to the capping position by a force applied edgewise thereof, thus permitting of the discs being preformed and arranged in stacks in containers, and avoiding the necessity of incorporating a disc forming mechanism in the capping machine.

A further object is to provide discs which are anti-nesting in the stack whereby they may be delivered from the bottom of the stack by known feeding means comprising feeding knives adapted to be inserted between adjacent discs.

The invention consists in a stacked series of bottle closure elements or discs formed of aluminium or other suitable metal foil, each disc having shallow corrugations or like formations extending over its surface which impart rigidity to the disc whereby it may be fed to a capping position by a force applied edgewise in the plane of the disc, the corrugations comprising at least two different designs, each disc in the stack having a design different from those of the adjacent discs on both sides thereof whereby the discs are anti-nesting.

The depth of the corrugations or the like in the closure element according to the

invention is such that the element still retains its disc-like character in that the formation of the corrugations or the like does not add materially to the thickness of the closure element.

The corrugations or formations according to the invention are preferably arranged to leave a plain marginal band and the periphery of the element is preferably slightly turned down.

The invention also includes a machine for forming a stacked container or carton of such anti-nesting discs in which two different designs of corrugations occur alternately in the stack, comprising a pair of disc stamping and embossing presses arranged for alternate operation, one press producing one of the designs, the other press producing the other design, and both delivering to guide means which feed the elements to the container.

In the accompanying drawings:—

Figure 1 is a partial view on an enlarged scale of a closure having one design of corrugation.

Figure 2 is a similar view of a closure having a different design of corrugation.

Figure 3 is a part cross section showing the closures of Figures 1 and 2 in stacked form.

Figures 4 and 5 are front and side elevations of a duplex closure forming machine.

Figure 6 is a part plan, and

Figure 7 is a partial view in section (viewed in the direction of the arrow X, Figure 5).

In carrying the invention into effect according to one convenient mode by way of example as applied to the capping of milk bottles, the closures comprise aluminium discs 1 or 2 which are pressed or cut out of sheets of aluminium foil of a suitable gauge. The gauge, it will be appreciated, is such that the discs are readily deformable and thus have substantially no inherent stiffness and in order

to provide the necessary stiffness for use, according to this invention, during the pressing operation the discs are provided with shallow stiffening corrugations or formations or embossing which may cover substantially the whole surface while leaving a peripheral margin free. The edge may be slightly turned down.

The design of the stiffening corrugations or formations may vary and may be of regular or irregular character, and with a view to avoiding nesting of the corrugations when stacked at least two distinct designs are provided. Thus one set of discs 1 may have radial embossments or corrugations 3 combined with a pair of concentric circular embossments or corrugations 4 while the other set 2 may have a spiral or a series of concentric circular embossments or corrugations 5.

The embossing formations 3, 4 and 5 are such that the discs 1 and 2 are rendered somewhat resistant to bending sufficient to stand up to an edgewise pressure in the plane of the disc during feeding to the capping position.

By having at least two different designs of embossing it will be appreciated that in placing discs 1 and 2 having alternate designs in a stack they will not nest one within the other. The depths of the embossing formations 3, 4 and 5 are such that when stacked the edges 6 and 7 of the discs will be spaced to permit the insertion of feeding means or knives between adjacent discs.

The discs 1 and 2 are adapted to be stacked in suitable containers or cartons and for this purpose where two designs of embossments are adopted a pair of disc forming and embossing machines or presses 9 and 10 may be provided.

These presses may be arranged at an angle to one another and are provided with suitable dies to form the corrugations or other stiffening formations, each die bearing a design different from that borne by the other die. The dies are such that plain marginal bands 12 and 11 are left on the discs 1 and 2 while the edges 6 and 7 of the discs are turned down or slightly cupped. The plungers of the presses are adapted for alternate operation and may be actuated by a common cam means.

The embossed discs as delivered are stacked in the container or carton.

A convenient arrangement of a pair of presses for stamping and embossing the closures is illustrated in Figures 4 to 7. A cam shaft 30 is provided with a pair of cams 31, 32 diametrically opposed which reciprocate die plungers 33, 34 co-operat-

ing with dies 35, 36. The die bed is arranged at an angle of about 45° to the horizontal so that the discs when cut out of strips and embossed by the plungers 33, 34 will slide down a chute 37 located between converging walls 38 and into a bell mouth sleeve or head 39. The head 39 is located above a container tube 40 into which the discs are stacked. As the plungers 33, 34 are alternately operated by the cams, the discs will be alternately stacked in the containers so that nesting of the corrugations formed by the dies will be prevented. The containers 40 are mounted in a rotary head carried by the spindle 41 by upper arms 42 and lower arms 43. The lower arms are provided with open ended shelf members 44 and are pivotally mounted on the hub 45, springs 46 being provided for holding the container within the head 39. The head 39 is provided with diametrically disposed side guides or ramps 47 to aid in positioning the tubes 40 under the spring action.

It will be obvious that two opposed series of presses may be provided so that a plurality of stacks of discs may be simultaneously formed.

Having now particularly described and ascertained the nature of our said invention and in what manner the same is to be performed, we declare that what we claim is:—

1. A stacked series of bottle closure elements or discs formed of aluminium or other suitable metal foil, each disc having shallow corrugations or like formations extending over its surface which impart rigidity to the disc whereby it may be fed to a capping position by a force applied edgewise in the plane of the disc, the corrugations comprising at least two different designs, each disc in the stack having a design different from those of the adjacent discs on both sides thereof whereby the discs are anti-nesting.

2. A container or carton having a stack of closure discs as claimed in claim 1.

3. A machine for forming a stacked container or carton as claimed in claim 2 in which two different designs of corrugations occur alternately in the stack, comprising a pair of disc stamping and embossing presses arranged for alternate operation, one press producing one of the designs, the other press producing the other design, and both delivering to guide means which feed the elements to the container.

Dated this 27th day of April, 1945.  
MARKS & CLERK.

715/40

7065

586,919 COMPLETE SPECIFICATION

[This Drawing is a reproduction of the Original on a reduced scale.]

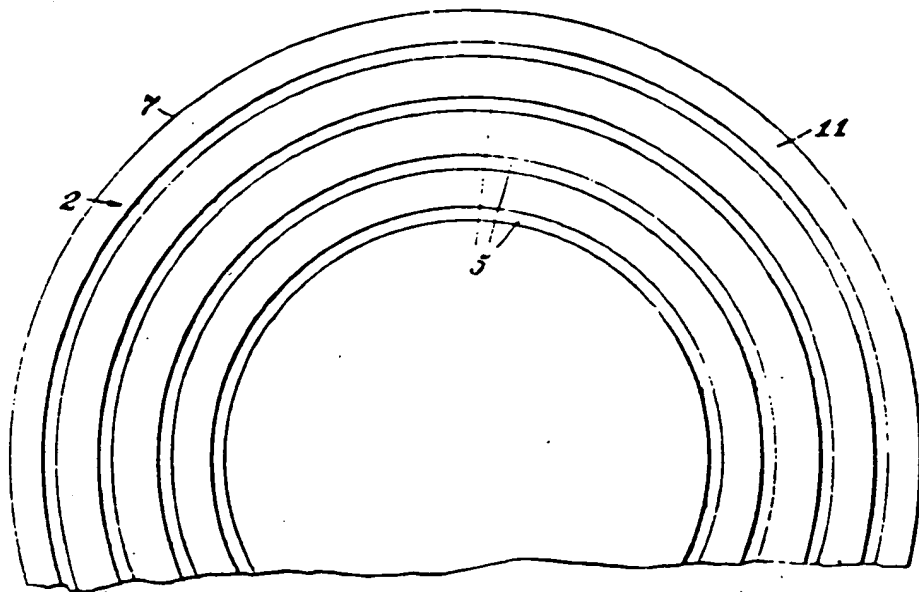

Fig. 1.

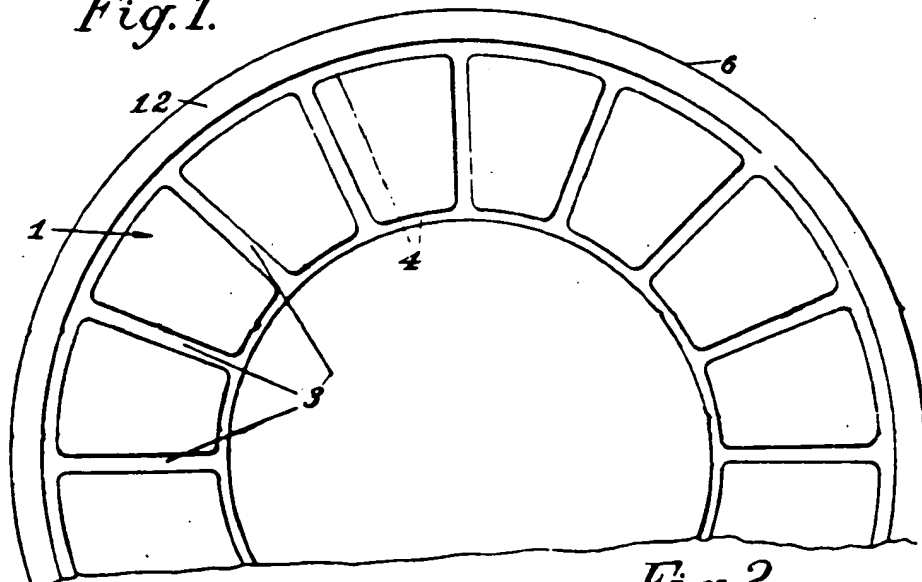

Fig. 2.

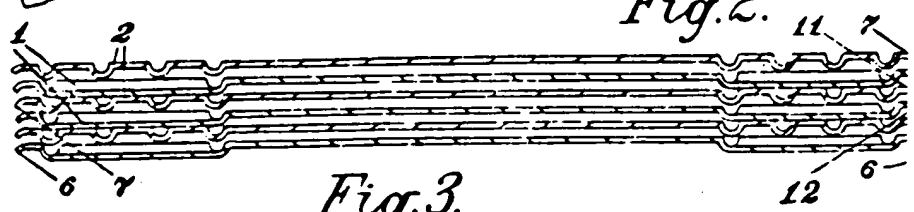

Fig. 3.

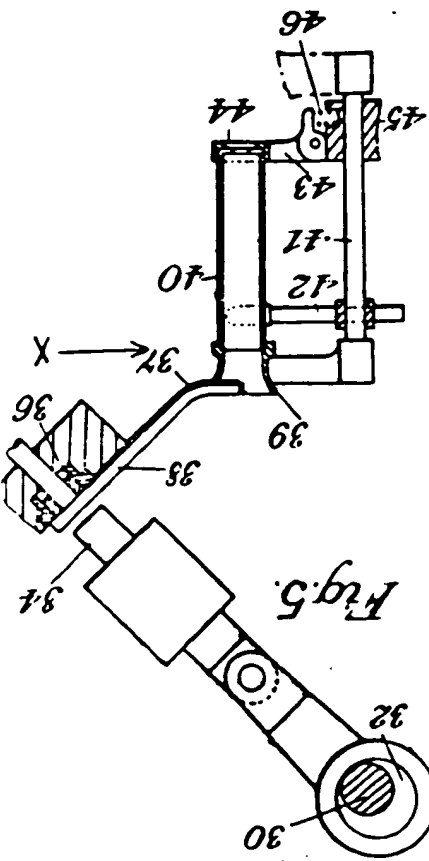

Fig. 6

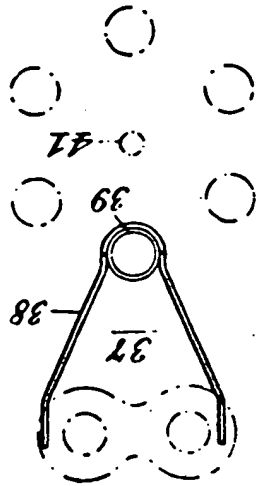

Fig. 7

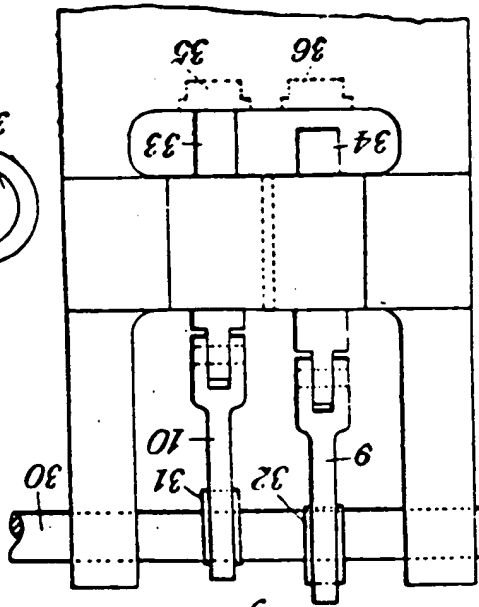
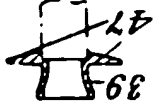

Fig. 4